

This document has 8 pages, registration forms are on pages 6-8.

AADTC Fall 2010 Class List

For Puppy Orientation or club information call 734-995-2801 or go to www.aadtc.org

PLEASE READ CLASS DESCRIPTIONS

***** One Star Classes have NO DOGS FIRST NIGHT.**

Section	Class	Instructor	# weeks	Starts	Day	Time	Room #	Cost
	Agility Screening	Instructors	1 week	9/16/10	Thursday	7 PM	Rm1&2	
601	5-12 mo. Pups STAR Pgm.	T&B Willoughby	7 weeks	9/27/10	Monday	6:15-7:30 PM	Rm 3	\$85
602	5-12 month Pups	J Blackledge	6 weeks	10/6/10	Wednesday	6-7 PM	Rm 4	\$70
603	5-12 month Pups (4 Week)	J Clear	4 weeks	9/9/10	Thursday	6-7:15 PM	Rm 3	\$55
604	5-12 month Pups (4 Week)	J Clear	4 weeks	10/7/10	Thursday	6-7:15 PM	Rm 3	\$55
605	Household 1 (C)*	J Koszednar	7 weeks	9/27/10	Monday	7:45-9 PM	Rm 3	\$85
606	Household 1	B Santure	7 weeks	10/12/10	Tuesday	10-11:15 AM	Rm 3	\$85
607	Household 2	P Bannick	6 weeks	9/20/10	Monday	6:30-7:30 PM	Rm 4	\$70
610	Novice 1	L Owens	7 weeks	9/16/10	Thursday	7-8:15 PM	Rm 4	\$85
611	Novice 2	P Bannick	7 weeks	9/20/10	Monday	7:45-8:45 PM	Rm 4	\$80
612	Novice 2	M Burney	7 weeks	9/30/10	Thursday	10-11:15 AM	Rm 3	\$85
613	Novice 3	R Hinmann	7 weeks	10/5/10?	Tuesday	6:15-7:15 PM	Rm 3	\$80
614	Rally Nov/Adv/Exc Practice	M Burney	7 weeks	9/27/10	Monday	7:45-9 PM	Rm1&2	\$85
615	Rally Nov/Adv/Exc Practice	M Burney	7 weeks	9/22/10	Wednesday	10-11:15 AM	Rm 3&4	\$85
616	Obedience Maneuvers Toolbox	P Bannick	4 weeks	11/8/10	Monday	6:30-7:30 PM	Rm 4	\$50
617	Novice/Open Practice	P Heinzelman	7 weeks	9/27/10	Monday	6:30-7:45 PM	Rm1&2	\$85
618	Open/Utility Comp Proofing	K Sweet	7 weeks	9/28/10	Tuesday	6-7:15 PM	Rm 4	\$85
620	Intro to Agility	D Grifka	7 weeks	9/23/10	Thursday	7:45-9 PM	Rm1&2	\$95
621	Beginner Agility 1	C Yarrington	7 weeks	9/23/10	Thursday	6:30-7:45 PM	Rm1&2	\$95
622	Agility Intermediate 1	J Ackley	7 weeks	9/21/10	Tuesday	5:15-6:30 PM	Rm1&2	\$95
623	Agility Competition 1	J Munday	7 weeks	9/21/10	Tuesday	6:30-7:45 PM	Rm1&2	\$95
624	Agility for Small Dogs	T Rhoades	7 weeks	9/21/10	Tuesday	7:45-9 PM	Rm1&2	\$95
625	Agility Weaves/Contacts	L Chomic	7 weeks	9/22/10	Wednesday	6-7:30 PM	Rm1&2	\$95
626	Agility Tech & Maneuvers	Chapman/Liebaert	7 weeks	9/22/10	Wednesday	7:30-9PM	Rm1&2	\$95
627	Agility Toolbox (4 weeks)	A Peterson	4 weeks	11/10/10	Wednesday	6-7:30 PM	Rm1&2	\$55
628	Agility Most Excellent Handling (4wk)	A Peterson	4 weeks	11/10/10	Wednesday	7:30-9 PM	Rm1&2	\$55
630	Urban Tracking (VST)	S Bauer	4 weeks	9/19/10	Sunday	8 AM	Various	\$70
other	AAKC Conformation		every	EVERY	Wednesday	7:30-8:30 PM	Rm 3&4	\$7

Where possible all confirmations will be via E-Mail. PLEASE ADD mepburney@ameritech.net to your address list to receive this email. Please contact the registrar (registrar@aadtc.org) if you have not heard from the AADTC by September 1. Confirmations by mail should be expected by the September 1 or two weeks before your class begins.

MAIL COMPLETED REGISTRATION FORM, INSTRUCTOR INFORMATION AND CHECK, PAYABLE TO 'AADTC'

To: AADTC Registrar, 2370 East Stadium Blvd. #365, Ann Arbor, MI 48104

Registration Deadlines: Members and Current Students: August 25th; All Students: Three weeks prior to the start of the class.

CLASSES WILL CONTINUE TO ENROLL UNTIL THEY ARE FILLED OR THEY START.

AADTC Registration Procedure

-Forms are processed on a first-come, first serve basis. Club members and Current students are given priority through the above deadline. Registration will continue until classes fill or class starts.

-One Registration Form per dog per class. Extra forms may be printed off your PDF or copy these forms.

-Because class size is limited, receipt of registration by the deadline does not guarantee a place in class.

-Class confirmations will arrive by email (if available) or mail after September 1.

-Please read class descriptions on class description pages on website or in your PDF.

Points of AADTC Policy

-Handlers wishing to take classes out of sequence or enter an advanced class without prior AADTC training must be screened by the Training Director or Instructor to ascertain eligibility.

-Handlers must be 16 years old. Exceptions are only achieved w/Training Director or by the Instructor.

-No refunds will be made after the second week of each term, unless the dog is excused by the Instructor.

-If an Instructor determines that a dog is a danger to the class, the dog will be excused and a refund given upon notification of the treasurer by the instructor.

-A processing fee of \$10 is assessed for refunds given after the cancel-by date.

-For checks returned by the bank the fee is \$20.

Member Notes -

- The cost of Obedience / Agility classes: 1 week (3 hours) \$15, 4-5 week \$25, 6-7 weeks=\$30 8-9 weeks=\$35 10-14 weeks=\$45

-All classes except tracking are free for instructors who have taught in the current calendar year. Tracking=\$50

-Official assistants get one class free for each class assisted.

Puppy Orientation- To register call 734-995-2801 or email puppy@aadtc.org or go to www.aadtc.org and follow the puppy classes information.

Conformation Classes (Dog Show Classes) Offered by AAKC (www.annarborkc.org). Every Wednesday in room 3. Cost: \$7

Ann Arbor Dog Training Club Registrar
2370 East Stadium Blvd. #365
Ann Arbor, MI 48104

RETURN PROMPTLY

CLOSING DATE: Three weeks before class starts
Members & Current Students: August 27

Some Classes may fill before closing date. No fax or registered mail accepted. Mail to above address only.

You must return a **completed and signed registration form**, **instructor information sheet for each class/dog**, and **check** to be considered for classes.

Incomplete forms will be rejected. This includes members!

FOR NON-MEMBERS:

TO REMAIN ON THE MAILING LIST,

RETURN THIS FORM

WITH ANY CORRECTIONS

START YOUR NEW PUPPY OFF RIGHT!

Puppy Orientation Classes

Beginner Classes, start 1st and 3rd Friday of each month at 7:45 PM for two weeks, then you will move to advanced classes. **Advanced Puppy Orientation classes** are offered 4 additional Fridays, for a total of 6 weeks. **Instructors will give you more information.**

- Puppy Socialization
- Basic Household Commands: come, sit, down, stay.
- Problem Solving Help: housebreaking, chewing, biting, jumping up, etc.
- Fee is \$10 per puppy per session, which you pay at the door. You may attend up to six sessions (Beginner class at 7:45 p.m., for two weeks, then up to four advanced classes at 6:15 - 7:30 p.m.).
- Puppies must be between 10-18 week of age at the first class.
- **You must bring** vaccination records and current fecal check results from your veterinarian.
- **Space is limited. To register – Call: 734-995-2801 or**

E-mail: aadogtrainingclubpuppy@yahoo.com.

(Pay at the door when you come to class)

The Ann Arbor Dog Training Club Canine Good Citizen Test

Have you just finished a class with your dog? Are you in a class with your dog? Do you want to let people know that your dog is recognized as a well-behaved "citizen"? Then come and take the Canine Good Citizen test.

Dates:

Practice for the CGC at 7:30-9 PM on Monday, September 13 in Room 1.

Canine Good Citizen Test: Monday, September 20, 7:30-9 PM in Room 1.

The cost is \$10 for the test and \$10 for the practice.

For further information go to www.aadtc.org.

Ann Arbor Dog Training Club - 1575 East North Territorial - 1 mile East of US-23

ANN ARBOR DOG TRAINING CLUB

Registrar: 2370 EAST STADIUM BLVD #365, ANN ARBOR, MI 48104

734-995-2801

www.aadtc.org

ANN ARBOR DOG TRAINING CLUB

The objectives of the Ann Arbor Dog Training Club are to conduct classes and occasional clinics and demonstrations in the training and care of dogs, and otherwise to disseminate knowledge wherever possible; to encourage and work with other groups and individuals with similar interests; to hold and support dog obedience trials and tracking tests according to the regulations of the American Kennel Club; to promote good sportsmanship in the training and exhibiting of dogs; and to promote public awareness and sensitivity to dog welfare.

The AADTC conducts regular social and training activities to stimulate the growth and development of the Club toward those objectives. Club meetings are held each month (guests are welcome) to discuss Club business and activities. Quite often a guest speaker is invited to share a viewpoint, update the Club on a new piece of dog-related legislation, or discuss dog health problems. The fall is a busy time of year with our annual tracking and obedience trials. Classes are held throughout the year along with fun matches and other miscellaneous activities. Occasionally we offer obedience or dog behavior clinics.

Our members have diverse interests and besides training for obedience competition, are also active in flyball competition, stock dog herding, field trials, tracking, agility, lure coursing, breeding and conformation showing. Some of our members are affiliated with the Humane Society, and a few offer private counseling.

AADTC MEMBERSHIP Information

You are welcome to attend club meetings, held the second Friday of each month at 7:30 PM at our training facility. **To become a member of the AADTC**, you will need to enroll in two classes offered by the club, attend meetings, and help at various club functions (Fun Matches, Work-Bees, Trials, Tracking Tests, Etc.), and be supported by two current club members and two instructors. This sounds intimidating, however it isn't if you are committed to having fun with dogs and people!

Conformation Classes (show dog classes) are offered by the Ann Arbor Kennel Club. For information concerning those classes or the Ann Arbor Kennel Club, contact: www.annarborkc.org

DIRECTIONS & Map to the AADTC building, 1575 East North Territorial Road.

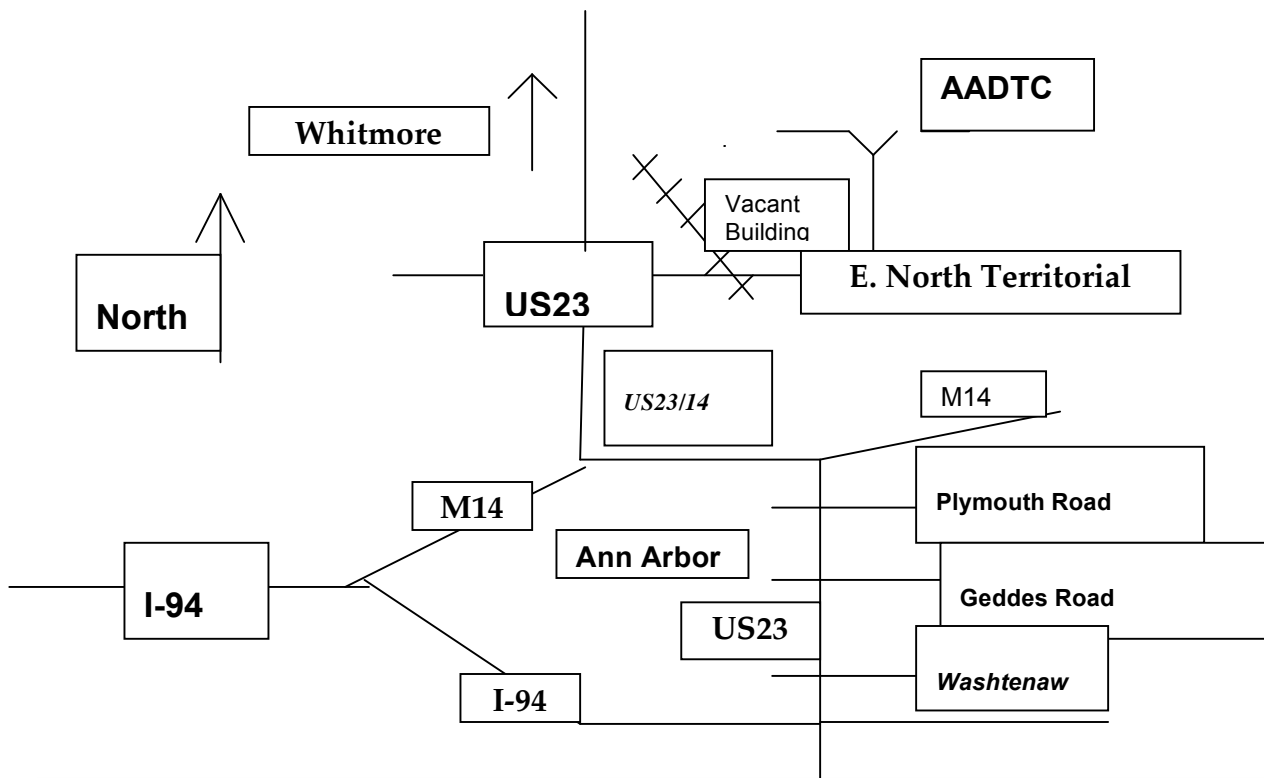

The AADTC is one mile **East** of U.S. 23, north of Ann Arbor. Going east on East North Territorial, you cross a railroad track, on your left will be a fenced vacant lot with big buildings on it. At the end of the fence is a driveway with our sign next to it. Turn left into the drive and stay to the right when you see the driveway divide. The Building is marked with room numbers and has two entrances for students- one on the far left and one in the middle. **Use this map, NOT Mapquest, unless you key in the address alone!**

AADTC COURSE DESCRIPTIONS –Fall 2010

The AADTC generally adheres to using the methods of positive reinforcement in our training.

The positive reinforcement used may be specific words, food, toys, or other training devices.

You may call to request the details of what is used in a particular class.

Household Obedience Classes

Please bring your dog to classes on a buckle collar and 4-6 foot cotton, nylon, or leather leash.

Please bring small soft treats and small non-rolling toys for your dog.

Unless otherwise noted on your confirmation email or below, please bring your dog to the first class.

KPT I (Kindergarten Puppy Training): Not offered this term For pups 10-18 weeks when class starts. Includes play session. See description below.

5-12 month Old Pups: For puppies too old for KPT up to 12 months. Geared for youngsters. See description below.

Household I AND Household 1(C): For dogs 6 months and up when class starts.

Classes 605 has No Dogs First Night.

See description below. **Household classes used to be called Beginner classes.**

This description applies to the three classes above: Focus on training of household manners to help dogs adapt to family life. Designed to teach basic control in a wide variety of situations with distractions. Exercises taught include sit, down, stand, stay, come and controlled walking. Most classes use food (treats) in training. Bring soft treats and silent dog toys. Check your confirmation card to determine whether dogs should attend the first night. **Household classes with a (C) sometimes have no dogs the first night. They use positive approach/No corrections. Classes with a (C) teach the effective use of the clicker and treats as positive reinforcement.**

5-12 Month STAR Program is a special program offered by AKC to promote awareness of training your puppies to be good citizens. Puppies and owners will learn how to train their dogs to meet the requirements for the Canine Good Citizen test, which we offer 4 times per year. This program is open to all puppies, both mixed and purebred

Household 2: Prerequisite: KPT I, Household I. Enhance your handling skills learned in your beginning class as above; continue working on skills for CGC (Canine Good Citizen), and start work on skills needed for Novice Rally, and obedience. Fun for both you and your dog. **Bring dogs and food treats first night.**

Tricks/Freestyle NOT OFFERED THIS TERM Prerequisite: Any Beginner, Puppy, or advanced class where the handler has basic control of the dog and the dog understands how to Sit, Down and Come on command. **Bring dogs and food treats first night.** It is recommended dogs be motivated by food. An introductory class, teaching you ways to teach your dog behaviors such as Tricks, Rally, and Freestyle (a form of dancing to music with your dog). Add some style to what your dog already knows. This class will introduce and use the principles of operant conditioning using positive reinforcement without the use of corrections. Luring, targeting, the use of an event marker (the clicker), and the proper use of food and toys will be discussed.

Competition Classes

Obedience Maneuvers Toolbox–Prerequisite: If you are interested in eventually showing at the Open and/or Utility level, consider this five week session covering some techniques and tools which can improve your training, proofing and polishing. Ideal for the training and proofing Open and Utility level exercises. **The dog may be at any level of training.** Learn some new methods to add to your existing obedience “toolbox”. This session **will not** cover training the Open and Utility level exercises, however.

Novice I: Prerequisite: Household 1, 5-12 month Puppy, or dogs aged 18 weeks and older with a handler with competition experience. **Course is geared toward obedience trials,** and emphasizes positive and motivational training with appropriate use of food in all exercises, as well as meticulous focus on an “obedience ring” foundation. **Clicker may be used.** The pace is slower with strong concentration of dog-attention, attitude and ways of offsetting the stress of concentrated training. **Priority is given to those committed to training for obedience trials.**

Novice 2: Prerequisite: Novice I with instructor approval to advance (screening will be required in all other cases). Continuation of motivational training geared toward competition in the obedience ring. Major subject matter: continued work on attention, heeling, precise maneuvers, recalls, start of figure eight.

Novice 3: Prerequisite: Novice 2 with instructor approval to advance (screening will be required in all other cases). Continue all attention and heeling work with emphasis on accuracy and attitude. Individual off-lead heeling including sits, pace changes, turns/about turns, recalls with fronts/finishes. Introduction to drop on recall and go-outs.

Rally Obedience The newest title offered by the American Kennel Club, the Rally Novice class is done on lead, and handlers are encouraged to talk to their dogs during the exercises. Judging, also, is less stringent than in formal obedience. **You are asked to bring a portable crate for your dog so that you can walk courses and do practice work without your dog.**

Rally Novice/Advanced/Excellent Class Practice* Prerequisite: Continuing students, Competition Basics, or the instructor’s permission. **Students are expected to have the basics of heeling, fronts, and finishes, and a general understanding of how to train their dogs.** Perfection is not expected and most students will be performing most exercises on leash. More advanced students will be encouraged to try to work off leash. There will be instruction on how to perform the various exercises and help with training the exercises scaled to the needs of the dog and trainer. Two nested courses/class.

Open: NOT OFFERED THIS TERM 7 weeks Prerequisite: Must have one leg on the CD of this dog. All novice exercises should be well trained and fully understood by the handler and dog. Basic novice maneuvers will not be taught. Suggestions will be given. Dumbbell will be discussed for ordering proper equipment. A couple exercises from each level will be taught and reviewed each week.

Utility: NOT OFFERED THIS TERM Prerequisite: Successful completion of Open or one leg on a CDX title. The foundation for the Utility exercises are introduced. Continued work on the precision heeling, now with the addition of signals. Introduction to signals, moving stand, go outs, directed jumping, gloves, and scent articles. Class may be repeated

Novice/Open: 7 weeks. Prerequisite: Dogs should know the foundations of each exercise at level of participation. This is not a run-thru. Practice at the Novice, Open levels will be offered every week. Attention, heeling will be the warm-up exercise at the beginning of the session, and varied Novice, Open exercises are done in split groups. Teaching of the various exercises is

supported. Instructor is willing to help students getting started with new exercises. Please indicate which level you wish to train by completing the description on your instructor information sheet. Observers are welcome. Please call for further information.

Open/Utility Competition Proofing: 7 weeks. Prerequisite: **Dogs showing in Open and training /showing in Utility.** Emphasis will be on competitive obedience at the Open and Utility level. Students will have ten minutes of individual attention and are expected to use the rest of the hour observing and learning how to improve communication and handling skills. Sits and Downs will be included. Observers are welcome. (Very small class, limited openings)

Advanced Heeling: **NOT OFFERED THIS TERM** Prerequisite: **Dogs ready for, or showing, in Novice/Open Obedience.** A class designed to perfect your heeling to a highly competitive level. Get that perfect sit and a dog that will stay with you at all times in the ring. Proofing in the stressful situation you will meet in the ring.

Agility Classes

Agility Screening: Thursday, September 16, at 7 PM

(Please be on time. All students, including members, who fail to come to screening for agility classes new to them and have not indicated this to the registrar, will be dropped.) Continuing students, ask your instructor which class you need.

Any dog that is a danger to itself or the class may be excused or placed elsewhere.

Note: Agility participants must help to set up and take down and/or move equipment and must be on time. This will take time at both the beginning and end of each class.

Introduction to Agility: Prerequisite: Successful completion of Beginner I, and/or Agility Screening. Dogs must have a reliable off-leash recall, sit, down, and brief stay. **For dogs over 1 year.* Attention given to agility maneuvers with emphasis on sending exercises, some series work, accuracy, control, motivation, and target training.**

*For exceptions to this, please talk to the instructors at screening.

Agility 5-12 Month Puppy: **NOT OFFERED THIS TERM** Prerequisite: Puppies must be between 5-12 months of age.

Beginner Agility: Prerequisite: Successful completion of Introduction to Agility, or Agility Screening. For dogs over 1 year of age. Graduated approach to agility training for beginning dogs/handlers. Emphasis is on learning obstacles safely, control on obstacles, and short series training.

Advanced Beginner Agility: Prerequisite: Successful completion of Beginner Agility or Agility Screening. Students are expected to be able to work contact obstacles at full height; introduction to longer sequences and full height jumping. Continues distance control and spatial relationships.

Agility Intermediate 1 Prerequisite: current students, successful completion of Advanced Beginner 2 Agility or Agility Screening. All contact obstacles are at full height; introduction to longer sequences and full height jumping, if possible. Continues distance control and spatial relationships.

Agility for Small Dogs: Prerequisite: Small dogs who have completed Intro to Agility. Multiple levels will be accommodated.

Competition Agility Prerequisite: Successful completion of Advanced Beginner Agility at the AADTC and/or Agility Screening. **Dog must be able to perform obstacles safely and be under off lead control.** You **must** be screened into these classes. This class is geared toward improving dog and handler performance of dogs currently competing in agility trials. Work will be on different "practice stations" and will concentrate on sequencing and fine-tuning the dog performance and will further refine dog and handler skills. All of these classes require that dogs be able to do full height jumps and know all of the contact obstacles and do them at full height.

Agility Competition 2: For dogs competing at the Novice and Open level.

Agility Competition 3: For dogs competing at the Open/Excellent level.

Agility Games and Run Throughs: **NOT OFFERED THIS TERM** Open/Excellent level dog ready to compete but not necessarily competing who want to have fun practicing their skills and learning new skills every week.

Agility Open/Excellent Run Throughs: **NOT OFFERED THIS TERM** Dogs working at the Open/Excellent level.

Run-Through courses will be both indoors and out of doors weather permitting. You may pay by the week or pay for 7 classes in advance (\$10/class, members, \$5). Classes will continue as long as there is interest during the summer. There will need to be a minimum number of people available to set up at 6 PM to run the class, and people will be needed to put equipment away.

Advanced Agility Techniques and Maneuvers –

For those dog/handler teams competing at the Open or Excellent level that are truly interested in enhancing/improving their performance thru the training/learning of newer and more in-depth techniques of handling, team communication and course analysis. Prepare to be challenged, **learn and train new techniques and maneuvers** and have a lot of fun!

Agility Toolbox (4weeks): Advanced/Open level using 6 weaves -Introducing Susan Garrett's Crate Games for motivation and weave proofing for dogs and handlers that are looking to work on entries to poles, work through distractions, and increase speed.

Agility Most Excellent Handling (4 weeks): Excellent/Masters level. This class uses Greg Derrett's handling system. Learn how to be consistent so your dog doesn't have any questions on the course. These exercises are designed to keep the experienced dog sharp and to expand your understanding of – lead outs, front crosses, serpentines, threadles, discriminations, lateral distances, etc..

Intro to Tracking: 7 weeks: NOT OFFERED THIS TERM .

Urban Tracking (VST): 4 weeks: Prerequisite: TD or TD certification: This 4 week tracking class focuses on the beginning levels of Urban tracking – Variable Surface Tracking Starts. Short aged tracks will begin on short grass – near parking lots, various landscaping features and near buildings and other structures. Emphasis on reliable article by the tracking dog will also be a priority. The class will meet a various locations within an hour's drive of the AADTC Building. Dogs entering this class must have their TD or TD certification. Class will meet on Sunday Morning at 8 AM September 19 and 26 and October 17, and 24.

No Flyball is offered this term. Any Questions? Call 734-995-2801.

INSTRUCTOR'S INFORMATION SHEET

Instructor _____

Return to AADTC Registrar, 2370 EAST STADIUM BLVD #365, ANN ARBOR, MI 48104

Please complete and return for all dogs in KPT, 5-12 Pup, Household 1 & 2, Agility, Flyball, Tracking, or any class not listed on other side of form! This form must accompany registration form, and check.

HANDLER

NAME _____ AGE (if under 18) ____ (Min. age is 16, without special Permission)

Address _____ E-mail address: _____

City _____ State _____ ZIP _____ Phone (____) _____ (H) (____) _____ (W)

DOG

CALL NAME _____ AGE (when class begins) _____ SEX _____

BREED * _____ (if puppy) DATE OF BIRTH _____

* If mixed breed, give approx. weight and height and possible breed combination:

Previous formal training of this dog? (List classes, instructors, dates and places):

TRY TO CLASSIFY YOUR DOG'S PERSONALITY (check any that apply):

- Friendly, outgoing Quiet, unmotivated
- Initially wary of strangers Aggressive toward people (inclined to snap)
- Hyperactive Aggressive toward dogs (inclined to fight)
- Timid Reserved
- Anxious or fearful (please describe) _____

SPECIFIC PROBLEMS YOU ARE ENCOUNTERING

- Difficult to control on leash Not housebroken Won't come when called
- Runs away if loose Plays too rough Dominant with children
- Noisy (barking/whining) Very distractible Growls
- Never settles down Resentful of discipline Chews
- Jumps on people Difficult to motivate

Dislikes or fears: Strangers Other dogs Children Dislikes or fears Loud Noises
Other _____

Is there anything else we should know about your dog and you? (The more we know, the better we can help.)

Has your dog ever bitten or snapped at a person or another dog? Yes No.

If yes, please describe circumstances (when, why, frequency, severity) on a separate sheet of paper and enclose with your registration materials. Has your dog has been in classes without incident since? Yes No

What would you like to gain *most of all* from this course?

ALL AGILITY CLASSES (Please complete in addition to the above info)

Has your dog done any jumping YES/NO What height? _____

Does your dog have a reliable, off lead, response to being called? Yes No

Does your dog "Down" on command? Yes No

Does your dog object to being handled anywhere on his body? If so, where? _____

What exposure or experience have you had to Agility training. (Seen on TV, or in person, taken clinic or class, etc.) _____

What is your reason for taking agility? _____

What is your skill level in agility? _____

What special performance difficulties or problems are you and your dog having? _____

INSTRUCTOR'S INFORMATION SHEET

Instructor _____

Return to AADTC Registrar, 2370 EAST STADIUM BLVD #365, ANN ARBOR, MI 48104

Please complete and return for all dogs in Competition Obedience Classes. This form must accompany registration form, and check.

HANDLER

NAME _____ AGE (if under 18) ____ (Min. age is 16, without special Permission)

Address: _____ E-mail address: _____

City _____ State ____ ZIP _____ PHONE (____) _____ (H) (____) _____ (W)

DOG

CALL NAME _____ AGE (when class begins) _____ SEX _____

BREED _____ (IF PUPPY) DATE OF BIRTH _____

(If mixed, size and guess at parents)

Previous formal training of this dog (list classes, instructors, dates, place, titles, legs) _____

Previous formal training of other dogs (List titles or legs)

SPECIFIC PROBLEMS

_____ Difficult to motivate _____ Previously "turned off" _____ Exceptionally soft _____ Tough
_____ Problems with other dogs _____ Splits off lead _____ Lacks self confidence _____ Overly eager

Other: _____

**** HAS YOUR DOG EVER BITTEN OR SNAPPED AT ANOTHER DOG OR PERSON _____ *****

Please explain circumstances and frequency. _____

What do you expect from this course? What is your ultimate goal in the obedience ring?

Do you expect to show soon? _____

If you are in Novice/Open Practice class: which level(s) __NOVICE __ OPEN

__ MORE THAN ONE DOG (please complete one instructor's sheet for each dog)

GENERAL EXERCISES

Attention: _____ Sniffing _____ Easily distracted in general _____ In the ring
Heeling: _____ Wide _____ Erratic _____ Crowds _____ Lags _____ Forges
About Turns: _____ Slow _____ Wide _____ Crowds
Sits: _____ Poor _____ No Sits _____ Dog does not know 'sit' in heel position
Off-Lead: _____ Poor on sits _____ On heeling _____ On about-turns
Stand for Exam: _____ Anxious _____ Moves feet _____ Moves away or sits
Recall: _____ Anticipates _____ Doesn't come on first command _____ Comes slowly
_____ Poor front _____ Poor finish _____ Will not stay on sit
Stays: _____ Breaks sit _____ Breaks down _____ Sniffs _____ Whines
_____ Shifts position _____ Interferes with other dogs

OPEN EXERCISES

Retrieve problems: _____

Drop Problems: _____

Jumping problems: _____

UTILITY EXERCISES

Signal problems: _____

Article problems: _____ Stops working _____ Tastes _____ Refuses to take article
_____ Works slowly _____ Generally unsure

Glove problems: _____

Go-Out problems: _____

Return Registration Form and Instructor Info with check to AADTC Registrar, 2370 East Stadium Blvd. #365, Ann Arbor, MI 48104 Need more forms? Go to www.aadtc.org

For Registrar's Use Only

Payment _____ Check # /Bank _____ Member _____ Non-Member _____ Current Student _____

Date Rec'd _____ Date Processed _____ Refund _____ Return _____ Prev. Wait List _____ Put on Wait List _____

AADTC REGISTRATION FORM

Incomplete forms will be returned. Copy both forms for multiple dogs OR multiple classes/dog.*
Print, clearly, include ZIP and Area Code

() *I do not wish to enroll at this time, but please keep me on the mailing list.*

Handler's Name

MINIMUM AGE IS 16
Handler's Age if under 18

Street Address

Dog's Name

Breed

City, State ZIP CODE

Sex

Date of Birth

E-mail address (PRINT CLEARLY) _____

Phone: Home () _____ Work () _____

If you are a former or current student of the Ann Arbor Dog Training Club, please indicate the most recent class attended:

Class Level: _____ Term/Year: _____ Instructor: _____

Class Choice: List all sections you are able to attend in order of preference. If this is your first class with us in agility, you MUST be screened.

Section	Class level/ title	Day/Time	Instructor
1.	_____	_____	_____
2.	_____	_____	_____
3.	_____	_____	_____
4.	_____	_____	_____

____ I will attend Agility Screening on Thursday, September 16 at 7 PM. (Please be on time. Students who fail to come to screening and have not indicated this to the registrar will be dropped.)

Do not detach.

NON-MEMBER TRAINEE HOLD HARMLESS AGREEMENT

This form must be signed by you in order to train your dog at the Ann Arbor Dog Training Club.

Your registration cannot be processed without your signature.

You will need to sign a similar form on your health card when your place in a class is confirmed.

IN CONSIDERATION of my being accepted as a non-member trainee of the Ann Arbor Dog Training Club,

I do hereby release and discharge the Ann Arbor Dog Training Club, its officers, members, and non-member trainees from any and all actions, claims, and demands for, upon, or by reason of damage, loss or injury which heretofore have been or which hereafter may be sustained by my person or property in consequence of my attending classes or other events sponsored by the above-named club and its members.

It is further agreed and understood that my acceptance as a non-member trainee is not to be construed as an admission on the part of said club, its officers, members and trainees of any liability in consequence of any accident or occurrence.

Date

Signature*

*If trainee is under 18 years of age, this form must be signed by parent or guardian.